

Description

The flail cutter is ideal for cutting overgrowth on construction sites as well as alongside roads and sidewalks. Adjusts to follow ground contour.

Dimensions

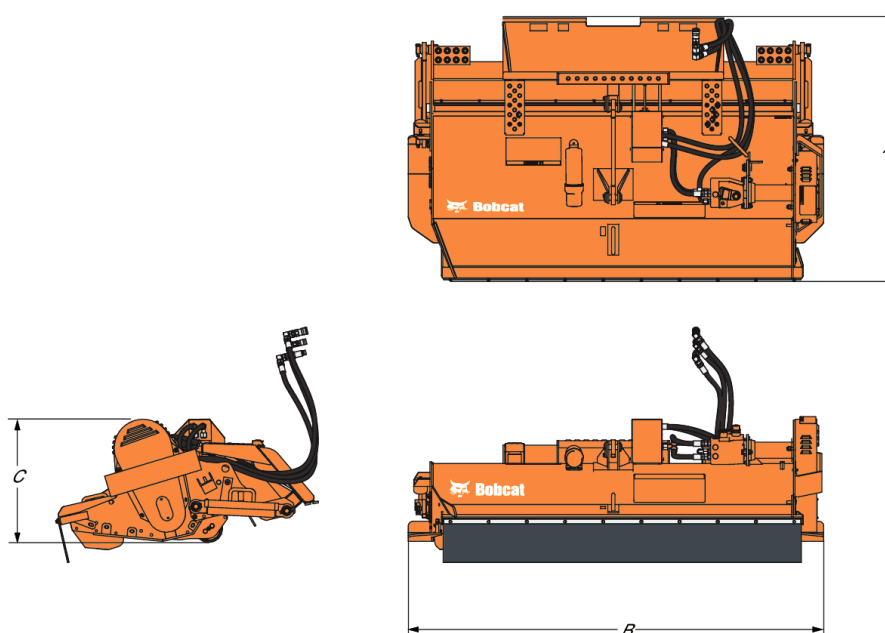

Description	Item number	Overall length (A) (mm)	Overall width (B) (mm)	Overall height (C) (mm)
Flail Cutter FC155	7115498	1457.0	1856.0	683.0
Flail Cutter FC175	7108385	1457.0	2056.0	683.0
Flail Cutter FC200	7101894	1457.0	2306.0	683.0

Weights

Description	Item number	Operating weight (kg)	Shipping weight (kg)
Flail Cutter FC155	7115498	580.0	580.0
Flail Cutter FC175	7108385	696.0	696.0
Flail Cutter FC200	7101894	746.0	746.0

Characteristics and performance

Description	Item number	Flow (L/min)	Max Drum speed (RPM)	Shut off float height (mm)
Flail Cutter FC155	7115498	64.0-151.0	2200.0	254.0
Flail Cutter FC175	7108385	64.0-151.0	2200.0	254.0
Flail Cutter FC200	7101894	64.0-151.0	2200.0	254.0

Main features

- Variable-speed displacement motor allows the flail cutter to be "tuned in" to your machine, depending on its hydraulic capacity. By varying the motor displacement to accept auxiliary hydraulic flows ranging from 64 to 151 l/min, the flail cutter can be operated on many different carriers.
- Floating linkage is standard on the flail cutter. This, along with the attachment's compact deck length, lets the unit follow the contour of the land regardless of the pitch or attitude of the carrier, permitting the cutter up to ten degrees of oscillation.
- Safety compliance The flail cutter complies with the SAE J1001 standard for industrial flail mowers. It is standard-equipped with an automatic shut-off device which allows approximately ten inches of vertical travel in the Bob-Tach™; mounting system before the flail cutter shuts down.
- Full-width tapered rear roller provides greater turning ability during operation.
- Adjustable rear hatch allows operators to vary the size of discharged material, ranging from small, for mulching applications to coarse for high-performance cutting.

Applications

- Agriculture
- Forestry
- Landscaping

Loader Compatibility

Description	Item number	Compatible with loader	Functional requirements
Flail Cutter FC155	7115498	T450E IIIB, T590E IIIB, T590B iT4, S450E IIIA, S450B T2, S510E IIIA, S510B, S530E IIIA, S530B, S550E IIIB, S550B iT4, S570B iT4, S590E IIIB, S590B iT4, S450 V, S510E V, S530E V, T590E V, T450E V, S66, T66, S510B, S530B, S550E V, S590E V	-
Flail Cutter FC175	7108385	A770-B, T590E IIIB, T590B iT4, S510E IIIA, S510B, S530E IIIA, S530B, S550E IIIB, S550B iT4, S570B iT4, S590E IIIB, S590B iT4, S630E iT4, S630B iT4, S510E V, S530E V, T590E V, S66, S76, T66, S510B, S530B, S550E V, S590E V, S630B iT4, S650B iT4	-

Description	Item number	Compatible with loader	Functional requirements
Flail Cutter FC200	7101894	A770-B, T590E IIIB, T590B iT4, T650E iT4, T650B iT4, T770E IV, T770E T3, T770B T3, T870E IV, T870B T3, S510E IIIA, S510B, S530E IIIA, S530B, S550E IIIB, S550B iT4, S570B iT4, S590E IIIB, S590B iT4, S630E iT4, S630B iT4, S770E IV, S770E T3, S770B T3, S850E IV, S850E T3, S850B T3, A770E IV, S510E V, S530E V, T590E V, S66, S76, T66, T76, S510B, S530B, S550E V, S590E V, S630B iT4, S650B iT4	-

BE OM **EN OFFERT**

Klicka bara på **knappen** eller skanna **QR-koden** nedan för åtkomst till vårt offertformulär.

Vi kontaktar dig så snart som möjligt. Tack!



BEGÄR OFFERT

