

Description

This powerful attachment puts concrete right where you want it. Built to last. Pumps concrete up to 75 m horizontally and two stories vertically. The hose is easily routed through small openings, under decks, through bushes and around other common obstructions. It reduces damage to turf and underground utilities caused by using large concrete trucks.

Dimensions

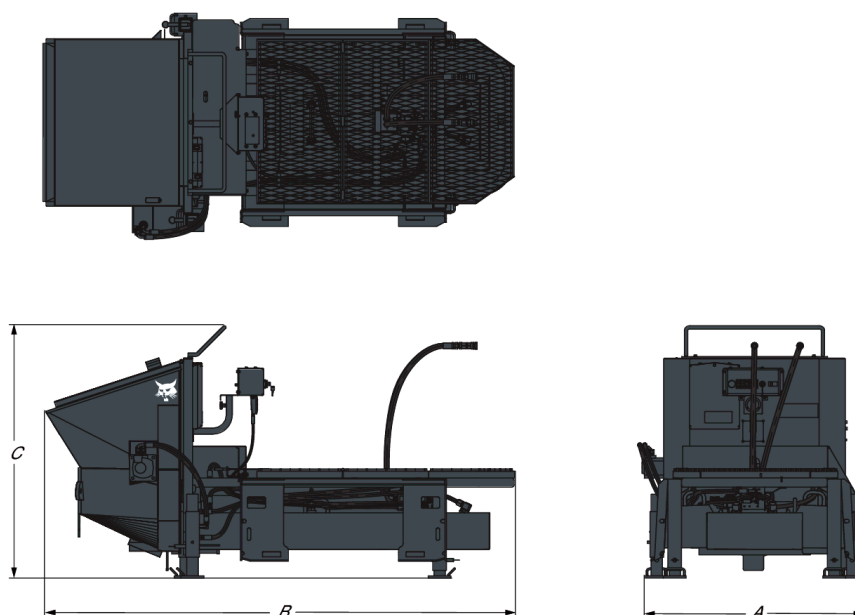

Description	Item number	Overall length (A) (mm)	Overall width (B) (mm)	Overall height (C) (mm)
Concrete Pump	7108693	1216.0	2615.0	1406.0

Weights

Description	Item number	Operating weight (kg)	Shipping weight (kg)
Concrete Pump	7108693	998.0	998.0

Characteristics and performance

Description	Item number	Hopper capacity (m3)	Vertical pumping height	Horizontal pumping distance	Pumping rate (m3/h)	Flow range [MIN]
Concrete Pump	7108693	280.0	0.0-15.0	0.0-75.0	13.0-23.0	56.0-151.0

Main features

- All pump components are guarded and easily accessible for adjustment and service.
- Control panel swivels for convenient operation from either side of pump.
- Protective guard panel strains larger objects from concrete mix.
- Attach-plates on both sides of pump make it easy to position in tight spots for either left- or right-hand delivery.

- Protects underground utilities from large concrete trucks.
- Keeps concrete trucks off driveways and sidewalks; prevents ruts in soft ground.
- Hose can be routed through small openings, under decks, through bushes, across rivers, around trees and buildings, over moguls.

Applications

- Construction and Demolition
- Road work, Recycling and Cleaning

Loader Compatibility

Description	Item number	Compatible with loader	Functional requirements
Concrete Pump	7108693	A770-B, T590E IIIB, T590B iT4, T650E iT4, T650B iT4, T770E IV, T770E T3, T770B T3, T870E IV, T870B T3, S550E IIIB, S550B iT4, S570B iT4, S590E IIIB, S590B iT4, S630E iT4, S630B iT4, S770E IV, S770E T3, S770B T3, S850E IV, S850E T3, S850B T3, A770E IV, T590E V, S66, S76, T66, T76, S630B iT4, S650B iT4	-

Accessories For Loader-Compatible Attachments

Description	Item number	Compatible with attachment	Functional requirements
Delivery System Kit for Concrete Pump	6906079	7108693 CONCRETE PUMP	-
Shotcrete Kit for Concrete Pump	6906861	7108693 CONCRETE PUMP	-
Remote Control for Concrete Pump	6906813	7108693 CONCRETE PUMP	-

BE OM **EN OFFERT**

Klicka bara på **knappen** eller skanna **QR-koden** nedan för åtkomst till vårt offertformulär.

Vi kontaktar dig så snart som möjligt. Tack!



BEGÄR OFFERT

